

INSTALLATION NOTES

NAVIGATOR

Touch Screen Keypad



Compatible with



NEC
CORPORATION

Installation

To open the Navigator Touch Screen keypad, release the four locking slots with a small screwdriver.

Install the back housing on a flat surface using the two slotted mounting holes provided.

The alignment arrow indicates the correct way up.

Navigator Keypad back housing.

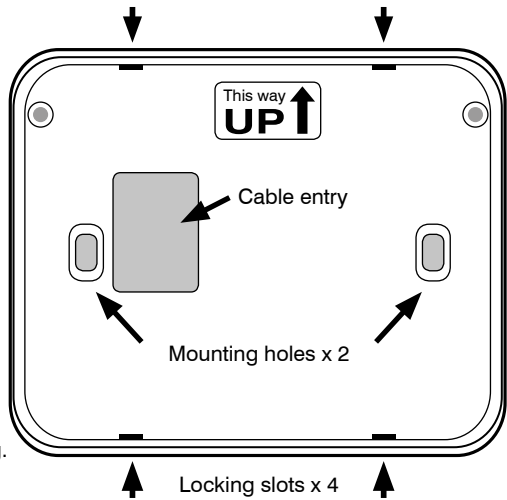

Wiring

Navigator Touch Screen Keypad should be wired to the control panel using minimum 7/020 security cable.

Up to four Navigator keypads can be connected per control panel as long as the maximum current draw for all detectors and keypads is below 500mA.

Maximum allowable cable distance is 100m including cable to all keypads.

Wire additional keypads in "star" configuration to the control panel.

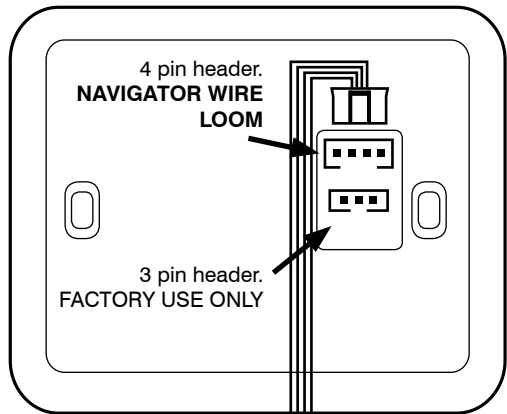

Navigator Keypad REAR

D8x / D16x V7 Main Board

	DAT	DAT	Blue
	CLK	CLK	White
	COM	COM	Black
	+12V	+12V	Red

Crimp connectors
(Supplied)

Applying the Protective Film

Navigator Touch Screen Keypad is supplied with a self-adhesive screen protector to help protect the sensitive touch surface from marks and scratches which may appear under normal use. We highly recommend you apply the film to keep your touch screen looking brand new for years to come.

STEP 1.

Use the Number 1 tab to peel off the self-adhesive backing.

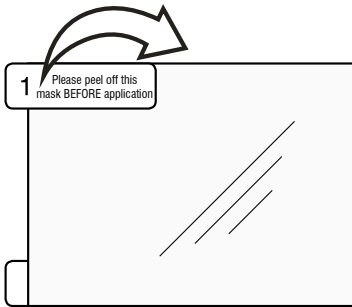

STEP 2.

Flip the film over to position the No. 2 tab at the top left.

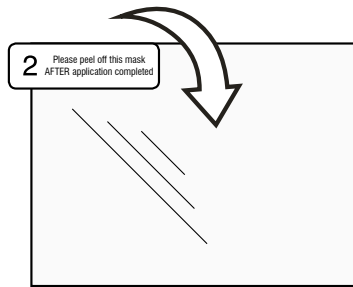

STEP 3.

Holding the protective film by the No. 2 tab, carefully apply the film to the Navigator's screen. Start applying at one end and smooth the film as you go to remove any air bubbles.

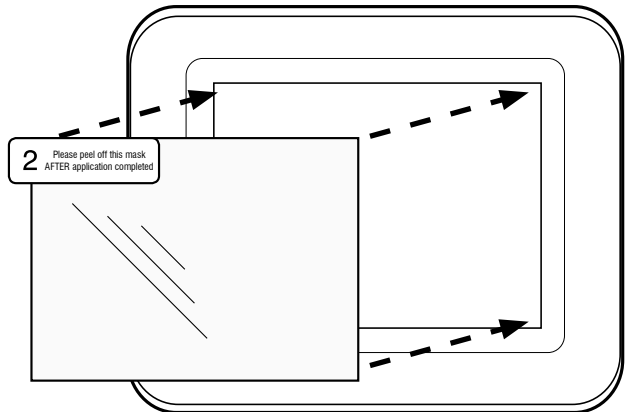

STEP 4.

Use the No. 2 tab to peel off and discard the topmost layer of the film. Your Navigator is now ready for use.

Compatibility

Navigator Touch Screen keypad is compatible with Ness D8x and D16x Version 7 and later control panels.

The keypad will display a warning if connected to earlier panel versions.



Specifications

DIMENSIONS	108w x 86h x 15d mm.
DISPLAY TYPE	3.5" Colour LCD
DISPLAY RESOLUTION	320 x 240
TOUCH SCREEN	Touch sensitive surface
COMPATIBILITY	D8x & D16x control panels version 7 and later
MAX. KEYPADS	4 x Navigator Touch Keypads per panel Maximum current draw for all detectors and keypads should not exceed 500mA.
OPERATING VOLTAGE	12VDC supplied by the control panel
CURRENT DRAW	25mA with 50% backlighting 50mA with 100% backlighting
DATA	2 wire proprietary Ness data bus



www.nesscorporation.com

National Customer Service Centre
Ph: 1300 551 991
customerservice@ness.com.au

NAVIGATOR TOUCH SCREEN KEYPAD
INSTALLATION NOTES
Rev 2, Apr13

Document Part Number: 890-411